

ABB Drives

**User's Manual
TTL Pulse Encoder Interface Module
RTAC-03**



TTL Pulse Encoder Interface Module
RTAC-03

User's Manual

3AFE68650500 REV A EN

EFFECTIVE: 10.02.2006

Safety instructions

Overview

This chapter states the general safety instructions that must be followed when installing and operating the RTAC-03 TTL Incremental Encoder Interface module.

The material in this chapter must be studied before attempting any work on, or with, the unit.

In addition to the safety instructions given below, read the complete safety instructions of the specific drive you are working on.

General safety instructions



WARNING! All electrical installation and maintenance work on the drive should be carried out by qualified electricians.

The drive and adjoining equipment must be properly earthed.

Do not attempt any work on a powered drive. After switching off the mains, always allow the intermediate circuit capacitors 5 minutes to discharge before working on the frequency converter, the motor or the motor cable. It is good practice to check (with a voltage indicating instrument) that the drive is in fact discharged before beginning work.

The motor cable terminals of the drive are at a dangerously high voltage when mains power is applied, regardless of motor operation.

There can be dangerous voltages inside the drive from external control circuits even when the drive mains power is shut off. Exercise appropriate care when working on the unit. Neglecting these instructions can cause physical injury or death.

Table of contents

Safety instructions	5
Overview	5
General safety instructions	5
 Table of contents	 7
 Introduction	 9
Intended audience	9
Before you start	9
What this manual contains	9
 Overview	 11
Overview	11
The RTAC-03 module	11
Module layout	11
Delivery check	12
Compatibility	12
 Installation	 13
General	13
Chaining	14
Setting the termination DIP switch (S2)	15
Removing the cover of the enclosure	15
Locating the termination DIP switch	15
Termination DIP switch settings	16
Mounting the RTAC-03 onto the RMIO board	17
Mounting the RTAC-03 onto an AIMA-01 I/O Module Adapter	18
Setting the node ID	18
Mounting	18

Wiring	19
Terminal designations	19
Cable recommendation	20
Phasing	20
Wiring diagram	21
Position latching	22
Programming the RTAC-03	22
Fault tracing	23
Diagnostic LEDs	23
CHA, CHB (Green)	23
WD/INIT (Yellow)	23
Installation problems	23
Option slot installation	23
AIMA-01 I/O Module Adapter installation	24
Technical data	25
RTAC-03 data	25

Introduction

Intended audience

The manual is intended for the people who are responsible for commissioning and using an RTAC-03 TTL Pulse Encoder Interface module with the ACS800 drive. The reader is expected to have a basic knowledge of electrical fundamentals, electrical wiring practices and how to operate the drive.

Before you start

It is assumed that the drive is installed and ready to operate before starting the installation of the extension module.

In addition to conventional installation tools, have the drive manuals available during the installation as they contain important information not included in this manual. The drive manuals are referred to at various points of this document.

What this manual contains

This manual contains information on the wiring, configuration and use of the RTAC-03 module.

Safety instructions are featured in the first few pages of this manual.

Overview contains a short description of the RTAC-03 TTL Encoder Interface module and a delivery checklist.

Installation contains instructions for module hardware settings, mounting and cabling.

Fault tracing explains fault tracing and the LED indications of the RTAC-03 module.

Technical data contains information on the physical dimensions, configurable settings, and connectors of the module.

Overview

Overview

This chapter contains a short description of the RTAC-03 Pulse Encoder Interface module and a delivery checklist.

The RTAC-03 module

The RTAC-03 module offers an interface for a TTL-type incremental pulse encoder connection. A TTL pulse encoder is used to obtain accurate speed or position (angle) feedback from the motor shaft.

Module layout

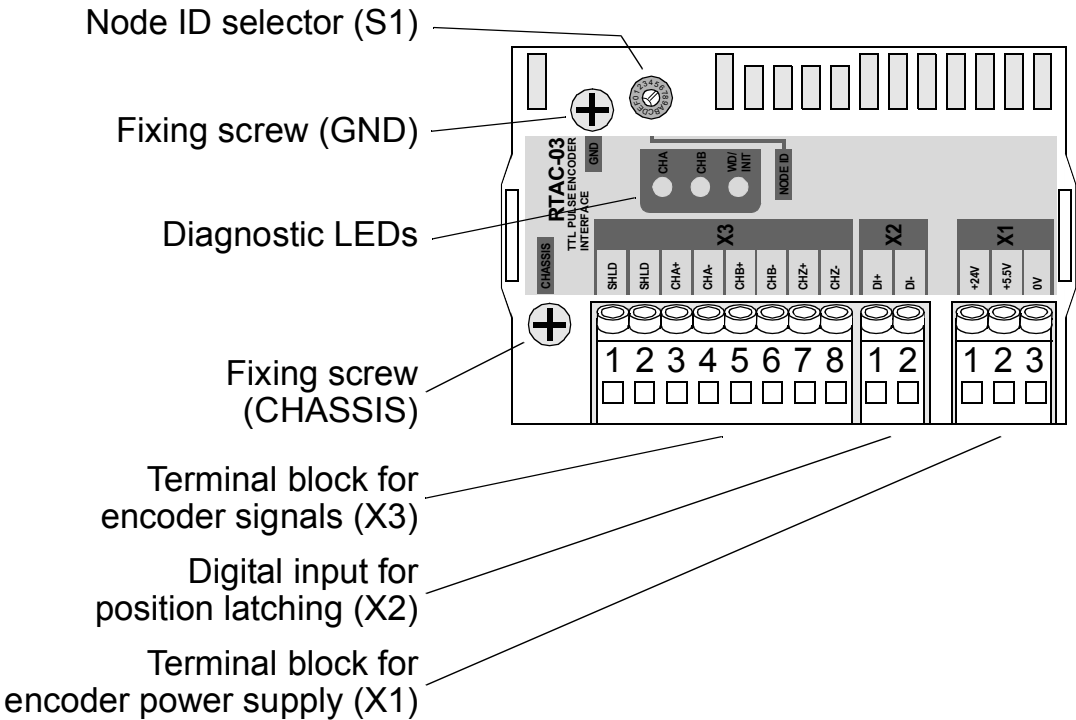

Delivery check

The option package contains:

- RTAC-03 module
- Two screws (M3×8 mm)
- This manual.

Compatibility

The RTAC-03 is compatible with the ACS800 Motion Control Application Program version APXR7100 or later.

Installation



WARNING! Follow the safety instructions given in this guide and the drive manuals.

General

The RTAC-03 is to be inserted into the position marked SLOT 1 or SLOT 2 on the drive. The module is held in place with plastic retaining clips and two screws. The screws also provide the earthing of the I/O cable shield connected to the module, and interconnect the GND signals of the module and the RMIO board.

On installation of the module, the signal and power connection to the drive is automatically made through a 38-pin connector.

The module can alternatively be mounted on a DIN rail-mountable AIMA-01 I/O Module Adapter.

Chaining

The encoder signals can be chained to several RTAC-03 modules. Whenever the encoder signals are chained to multiple modules, the termination should be switched off on all modules in the chain except the last one.

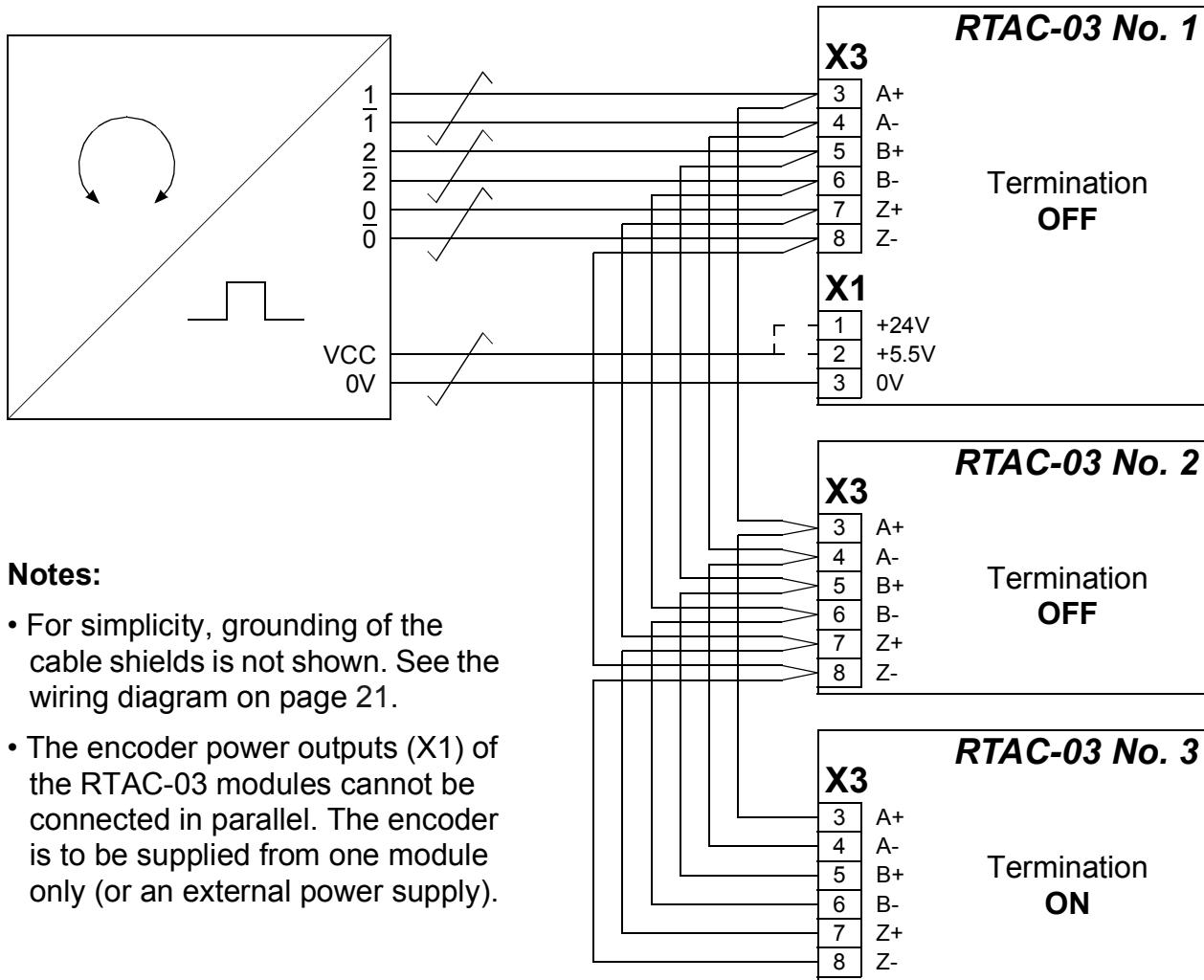

Notes:

- For simplicity, grounding of the cable shields is not shown. See the wiring diagram on page 21.
- The encoder power outputs (X1) of the RTAC-03 modules cannot be connected in parallel. The encoder is to be supplied from one module only (or an external power supply).

Because the termination switch is located inside the housing of the module, it is practical to set the switch before the module is mounted and wired.

Setting the termination DIP switch (S2)

Removing the cover of the enclosure

In order to access the termination DIP switch, the cover of the module enclosure must be removed. This can be done by carefully bending the two cover retaining clips with a small screwdriver and lifting the cover off.

Refit the cover by pushing it back into its place until the retaining clips lock it into position.

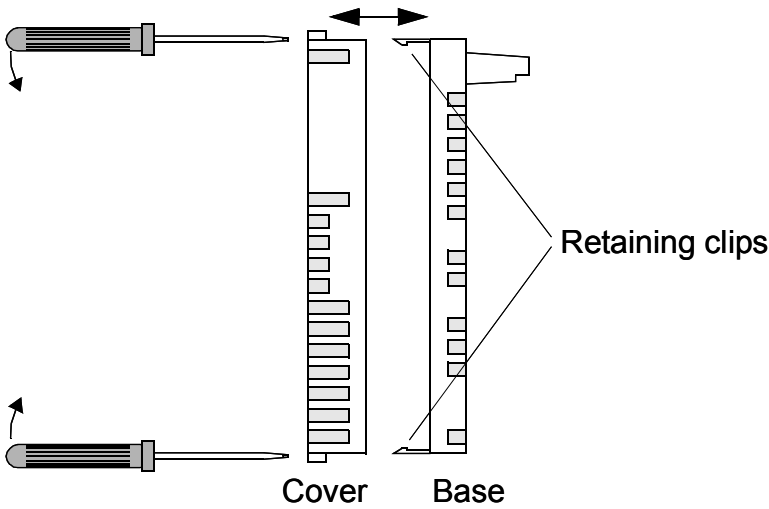

Locating the termination DIP switch

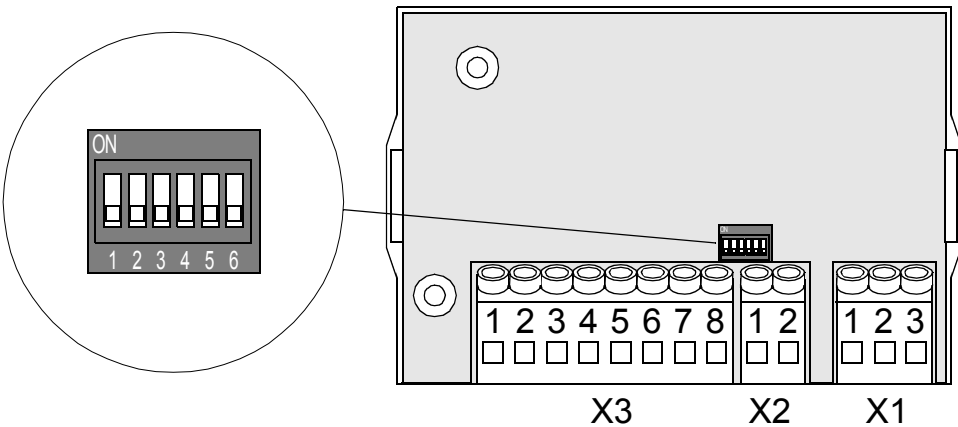

Termination DIP switch settings

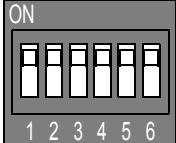
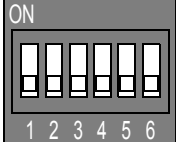
Termination	Switch setting
ON (default)	
OFF	

Mounting the RTAC-03 onto the RMIO board

1. Insert the RTAC-03 carefully into SLOT 1 or SLOT 2 on the RMIO board until the retaining clips lock the module into position.
2. Fasten the two screws (included) to the stand-offs.

Note: Correct installation of the screws is essential for fulfilling the EMC requirements and for proper operation of the module.

Mounting the RTAC-03 onto an AIMA-01 I/O Module Adapter

Before mounting the module onto the AIMA-01, the node ID must be set.

Setting the node ID

Choose the proper node ID for the module using the selector switch S1. The settings 0 ... F correspond to node IDs 16 ... 31. The default setting is 0 (node ID 16).

For the correct node ID number, see the appropriate *Firmware Manual*.

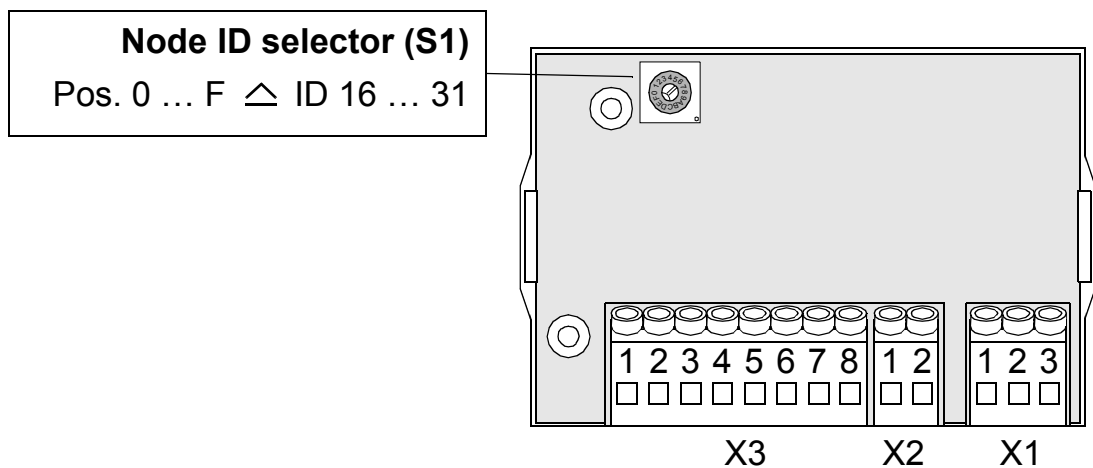

Mounting

1. Insert the RTAC-03 carefully into a free slot on the AIMA-01 I/O Module Adapter until the retaining clips lock the module into position.
2. Fasten the two screws (included) to the stand-offs.

Note: Correct installation of the screws is essential for fulfilling the EMC requirements and for proper operation of the module.

Wiring

Terminal designations

X1	Marking	Description
1	+24V	+24 V power for 10 to 30 volt encoders (210 mA max.).
2	+5.5V	+5.5 V power for 5 volt encoders (300 mA max.).
3	0V	Common.

X2	Marking	Description
1	DI+	Digital input for position latching. <ul style="list-style-type: none"> • 24 V logic • < 5 V = "0", > 15 V = "1" • Absolute maximum voltage: +30 V • Absolute minimum voltage: -3 V
2	DI-	The usage of this input depends on the application program of the drive; see the appropriate <i>Firmware Manual</i> delivered with the drive.

X3	Marking	Description
1	SHLD	For earthing of the encoder cable shields. Internally connected to the frame.
2	SHLD	
3	CHA+	<ul style="list-style-type: none"> • Max. signal frequency: 200 kHz • Signal levels: RS422/RS485, differential • Input channels isolated from the logic, power supply, and earth • When the drive runs in the <i>Forward</i> direction, channel A should lead channel B by 90° (electrical) • Channel Z: One pulse per revolution (used in positioning applications only)
4	CHA-	
5	CHB+	
6	CHB-	
7	CHZ+	
8	CHZ-	

Cable recommendation

The encoder should be connected to the RTAC module with a cable specified below.

Cable construction	4 × (2+1) Twisted pair cable with individual and overall shields.	
Conductor cross-sectional area	0.5 to 1.0 mm ²	
Maximum cable length	With a 5 volt encoder (+5.5 V output) (0.5 mm ² cable):	30 m
	With a 5 volt encoder (+5.5 V output) (1.0 mm ² cable):	60 m
	With 10...30 volt encoder (+24 V output) or external power supply:	100 m

Note: The cable shields should be earthed only at the RTAC module if the pulse encoder is not isolated from the motor and earth. However, if the encoder is isolated from the motor and earth, the cable shields are to be connected to the encoder housing also.

Note: Do not route the pulse encoder cables parallel to power (eg. motor) cables.

Phasing

When the pulse encoder is connected correctly, running the drive in the *Forward* (positive speed reference) direction should produce a positive encoder speed feedback.

Wiring diagram

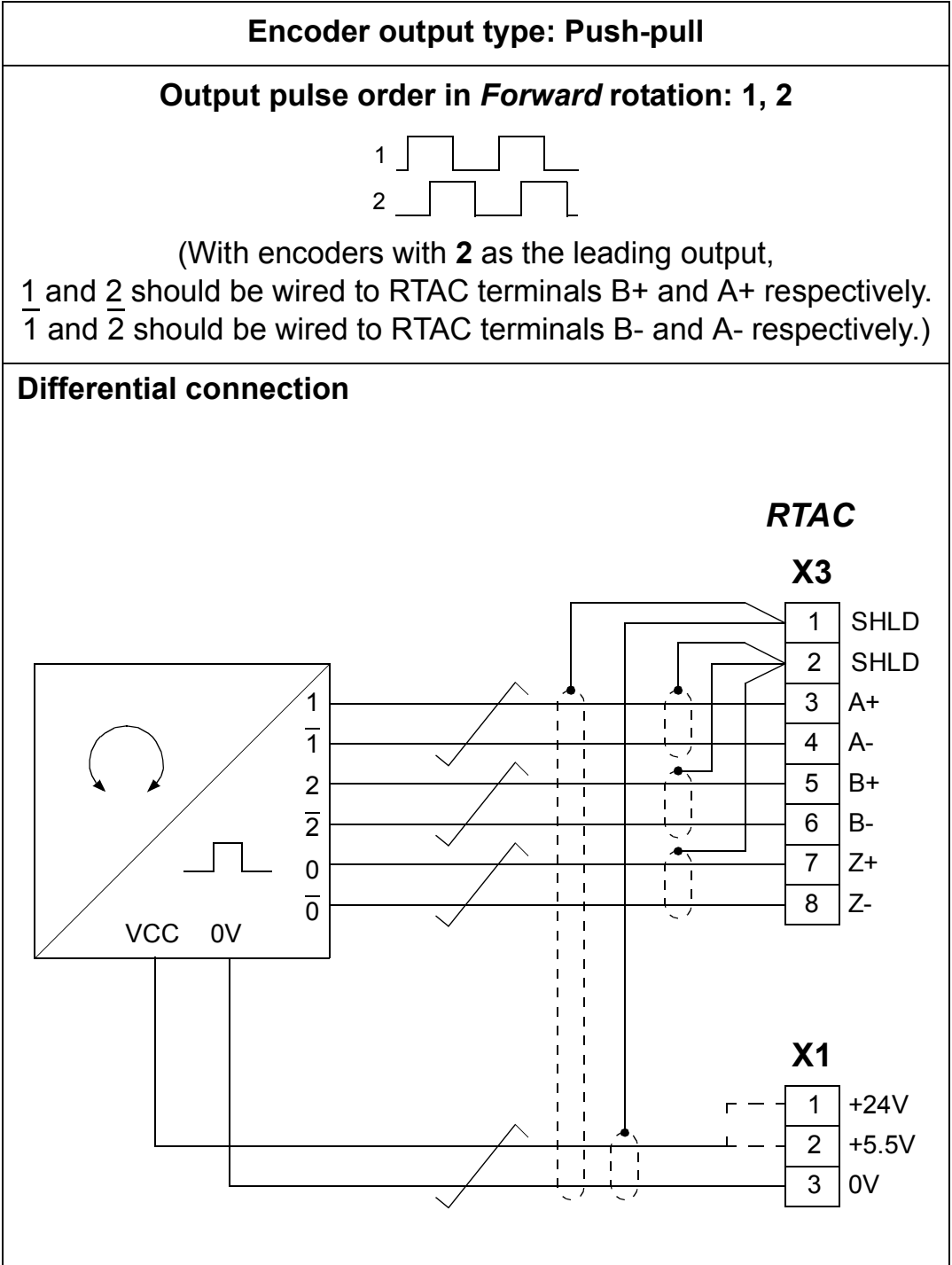

Position latching

The digital input on the RTAC-03 can be used for position latching provided it is supported by the application program. For more information, see the drive *Firmware Manual*.

Programming the RTAC-03

The RTAC-03 is programmed through drive parameters. These parameters must be checked and adjusted. For further information, see the drive *Firmware Manual*.

Fault tracing

Diagnostic LEDs

There are three diagnostic LEDs on the RTAC-03 module.

CHA, CHB (Green)

These LEDs show the activity on channels A and B as generated from the encoder output signal.

WD/INIT (Yellow)

This LED shows the status of the module. The LED is lit when the drive is configuring the module at power-up. It can also be lit after power-up if an error occurs in the communication between the drive and the RTAC-03 (see *Option slot installation* below).

Installation problems

Option slot installation

In case the WD/INIT LED does not go out after about 5 seconds:

- The configuration has failed.
 - Cycle the power supply of the drive.
- The module has a hardware failure.
 - Ensure the 38-pin connector is properly inserted.
 - Contact an ABB service representative.

AIMA-01 I/O Module Adapter installation

- There is no communication with the drive.
 - Check that the drive is powered.
 - Check the module node ID.
 - Ensure the 38-pin connector is properly inserted.
 - Check the parameter settings of the drive.
 - Contact an ABB service representative.

Technical data

Dimensions:

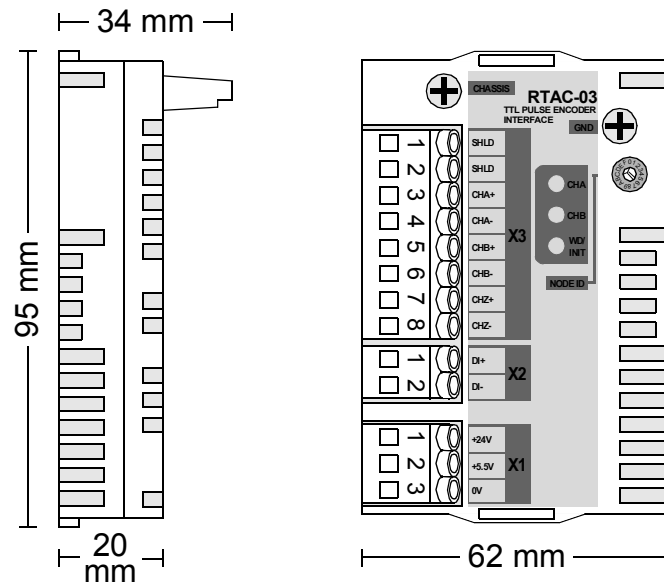

Mounting: Into an option slot of the RMIO board of the drive or onto external I/O Module Adapter (AIMA-01).

Degree of protection: IP20

Ambient conditions: The applicable ambient conditions specified for the drive in its *Hardware Manual* are in effect.

Hardware settings:

- Rotary switch for node ID selection (range 16...31)
- Termination switches for encoder signals CHA, CHB and CHZ.

Connectors:

- 38-pin parallel bus connector
- One 3-way, one 2-way, and one 8-way non-detachable screw-type terminal block for max. 2.5 mm² wire.

Encoder interface:

- Encoder type: TTL-type incremental pulse encoder with a supply voltage of 5 V or 10...30 V
- Encoder voltage output: 5.5 V DC (300 mA) or 24 V DC (210 mA), short-circuit proof, isolated
- Signals: CHA, CHB, CHZ (RS422/RS485, differential)
- Maximum frequency: 200 kHz
- Maximum cable length: See table on page 20.
- Speed feedback resolution: 0.00305% (15 bits)
- Speed feedback accuracy: 50 ppm
- Isolated from the logic and earth

Digital (position latching) input:

- 24 V logic
- $< 5 \text{ V} = "0"$, $> 15 \text{ V} = "1"$
- Absolute maximum voltage: 30 V
- Absolute minimum voltage: -3 V

Max. power consumption: 150 mA (5 V) + 300 mA (24 V)

Estimated min. lifetime: 100 000 h

Miscellaneous:

- All materials UL/CSA-approved
- Complies with EMC standards EN 50081-2 and EN 50082-2



3AFE68650500 REV A EN
EFFECTIVE: 10.02.2006

ABB Oy

AC Drives
P.O. Box 184
FIN-00381 HELSINKI
FINLAND
Telephone +358 10 22 11
Fax +358 10 22 22681
Internet www.abb.com

ABB Inc.

Automation Technologies
Drives & Motors
16250 West Glendale Drive
New Berlin, WI 53151
USA
Telephone 262-785-3200
800-HELP-365
Fax 262-780-5135

ABB Beijing Drive Systems Co. Ltd.

No. 1, Block D, A-10 Jiuxianqiao Beilu
Chaoyang District
Beijing, P.R. China, 100015
Telephone +86 10 5821 7788
Fax +86 10 5821 7618